

版本 REV.	日期 DATE	ECN NO.	变更内容 DESCRIPTION	制图 DRAWN

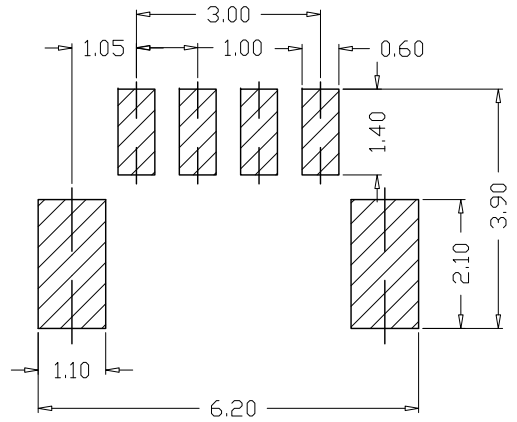

PCB LAYOUT

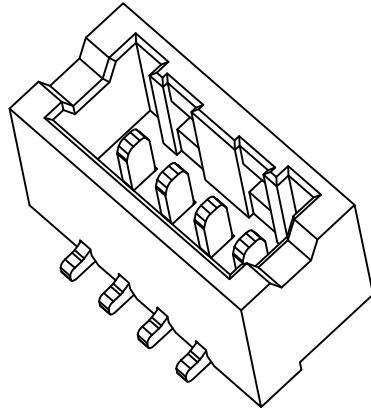
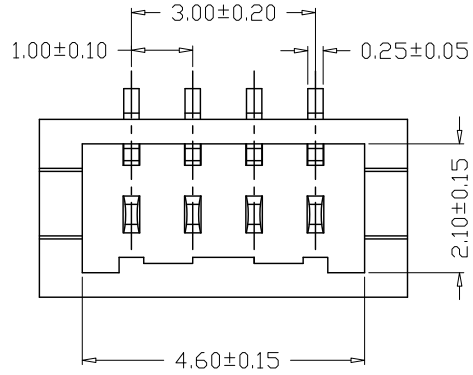
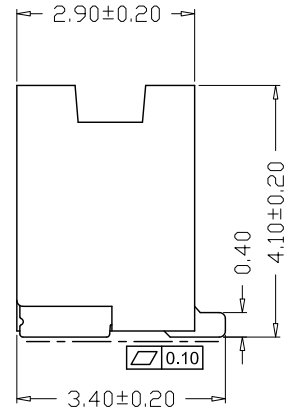
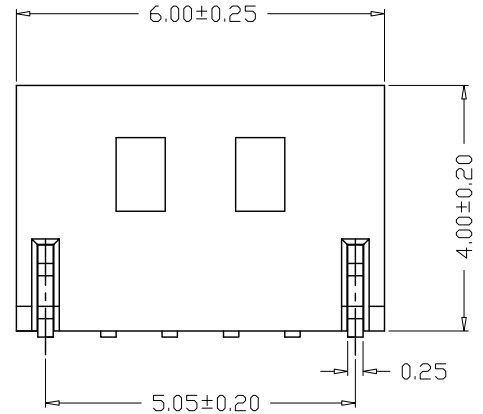

SPECIFICATIONS

- Current Rating: 1.5A AC, DC
- Voltage Rating: 150V AC, DC
- Temperature Range: -25°C~+130°C
- Contact Resistance: 20mΩ Max
- Insulation Resistance: 1000MΩ Min
- Withstanding Voltage: 900V AC/minute
- Material  
Wafer: LCP UL94V-0  
PIN: Brass Tin-plated  
Fixed piece: Brass Tin-plated

GENERAL TOLERANCE		制图 Mapping	张迎春 2022、08、26		料号 PART NO.	B10019-4AB		版本 REV.	A	
X±0.25	X°±2°	审核 Audit	钱岳生 2022、08、26		品名 TITLE	1005966 立贴 WAFER SMT TYPE		页次 SHEET	1/1	
.X±0.25	.X°±1°	核准 Approved	张名 2022、08、27		客户料号 CUTM. NO.					
.XX±0.15	.XX°±0.5°	单位 Units	mm	比例 SCALE	乐清市宏一电子有限公司 YueQing HongYi Electronics Co., Ltd					
.XXX±0.10	.XXX°±0.5°									